

BOOTH DESIGN REGULATIONS

PLEASE BE SURE TO READ THE FOLLOWING INFORMATION IN ITS ENTIRETY AND DISTRIBUTE TO YOUR STAFF AND EXHIBITOR APPOINTED CONTRACTORS. THESE REGULATIONS WILL BE STRICTLY ENFORCED.

BOOTH TYPES & HEIGHT REGULATIONS

- ❖ **In-line/Linear booth** bounded by 1 or 2 aisles
 may build up to 8'

- ❖ **Island Booths** bounded by 4 aisles and is 20' x 20' or larger
 may build up to 12'

- ❖ **Peninsula Booths** bounded by 2 or 3 aisles and is 20' x 20' or larger
 may build up to 12'

- ❖ **Perimeter Booths** inline/linear booth located on the outer perimeter wall of the exhibit
 floor may build up to 12'

DISPLAY REGULATIONS

The following rules governing what an exhibitor can and cannot do with his booth space are based on the physical characteristics of the hall, the wish to be equally fair to all exhibitors, and the safety of all concerned.

THE CUBIC CONTENT RULE:

This event follows the cubic content rule, which allows exhibitors to make maximum use of their booth space. Under the cubic content rule, each exhibitor may build right up to the front of the booth, up to the maximum allowable height. The height varies according to the booth type, as shown in the height regulations section above and sketch on page 3. This height restriction includes but is not limited to Banners, Flags, Tents and Lighting. **As a courtesy to your neighbor, please take your neighbor's visibility into account. Consider using smoked plexiglass as opposed to solid walls, and placing your equipment further into your booth as opposed to blocking line of sight.**

BOOTH WALLS MUST BE FINISHED:

All back walls and sidewalls must be finished or draped, no loose wire or any obstruction may be seen or Event Management, at the exhibitor's expense, will drape them. See-through back walls or displays that do not cover the back wall entirely will not suffice. **All walls facing into a neighboring booth must be devoid of copy, logos or other graphics.**

COVERED STRUCTURES, TENTS & DOUBLE-DECKER/TWO-STORY EXHIBITS:

Fire and safety regulations in many facilities strictly govern the use of canopies, ceilings, and other similar coverings. **If your booth type permits any type of cover/tent or multiple stories exhibit, you are subject to additional fire & safety regulations and show management approval.**

BOOTH DESIGN REGULATIONS

DEMONSTRATION EQUIPMENT:

Equipment, product or machinery when displayed to demonstrate or simulate industrial application are exempt from the foregoing height limits, but are restricted only by ceiling height, as well as building and safety codes. The excess height must be a result of the actual height of the equipment from the exhibit hall floor to the top of the equipment. No graphics, signage, logos, etc. may be posted on equipment above the height limit for your booth type. Contact Show Management if your product will exceed your maximum allowed height.

GOOD TASTE AND THE RIGHTS OF OTHERS:

Show Management may require any exhibitor to make changes in your exhibit if, Event Management's opinion the exhibit does not conform to the prevailing standards of good taste or interferes with the rights of other exhibitors.

HANDOUTS:

You cannot distribute literature, samples or other materials outside your contracted exhibit space. The distribution of any samples, literature or other materials from a non-exhibiting company (one without a contract to exhibit) is expressly prohibited without prior written consent of Event Management. The rule does not apply to exhibiting publishers who distribute their own magazines that contain non-exhibitor advertising. No literature may be distributed outside of your booth.

HANGING SIGNS:

Hanging signs over your booth with rigging from the ceiling is **NOT** permitted in the Exhibit Hall.

MATERIALS AND OTHER ADHESIVES:

Nothing may be posted, tacked, nailed or screwed to columns, walls, floors or other parts of the building. Event Management will remedy any damage or defacement caused by infractions of this rule at the exhibitor's expense.

STORAGE:

Fire regulations prohibit storing product, literature, empty packing containers or packing materials behind back drape. In most cases, however, exhibitors may store a limited supply of literature or product appropriately within the booth area, so long as these items do not impede access to utility services, create a safety problem or look unsightly.

SOUND LEVELS:

Music may not exceed background audio level. All speakers must be facing into the exhibitor's booth and not away from the booth. Loudspeakers and carnival tactics will not be allowed. Please be a considerate neighbor. Sound level of presentations should be kept within the confines of the booth area and must not interfere with neighboring exhibits. Event Management reserves the right to shut down any receptions, presentations, or other activities which are deemed obstructive or prohibitive for neighboring booths to be able to conduct business.

PERSPECTIVE VIEW

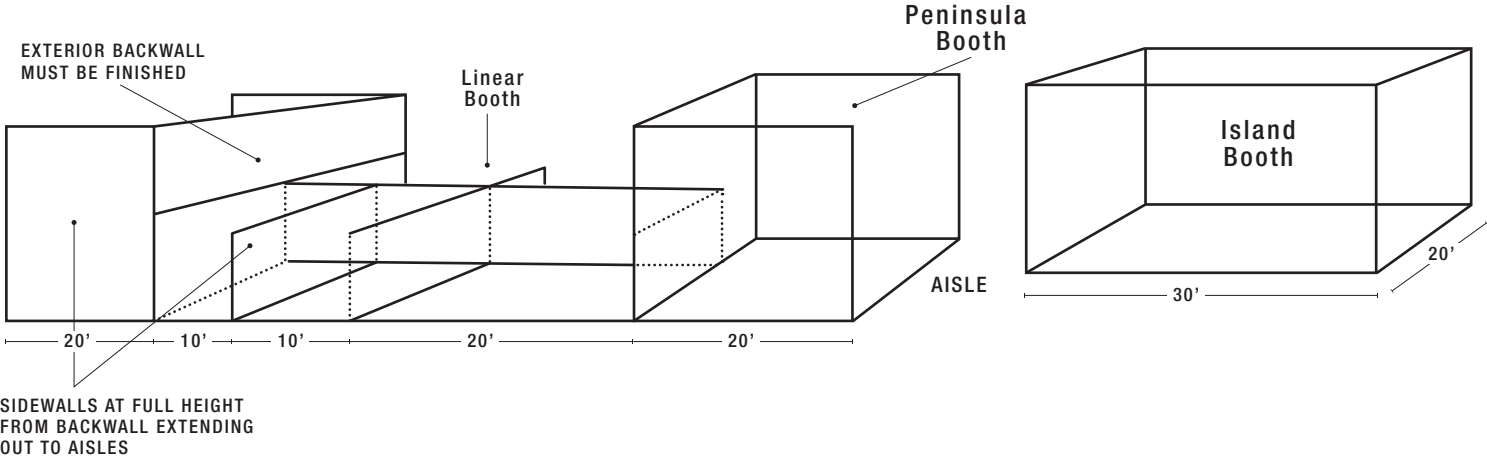

PLAN VIEW

